

		REVISION	NAD	APPROVAL	SCHEDULE
ITEM	PROVIDE	SIGNATURE	PROVIDED	1RST.	
REVISION	ANT.		ACT.		
APPROVAL	DATE:		FINAL:		

# LV-09

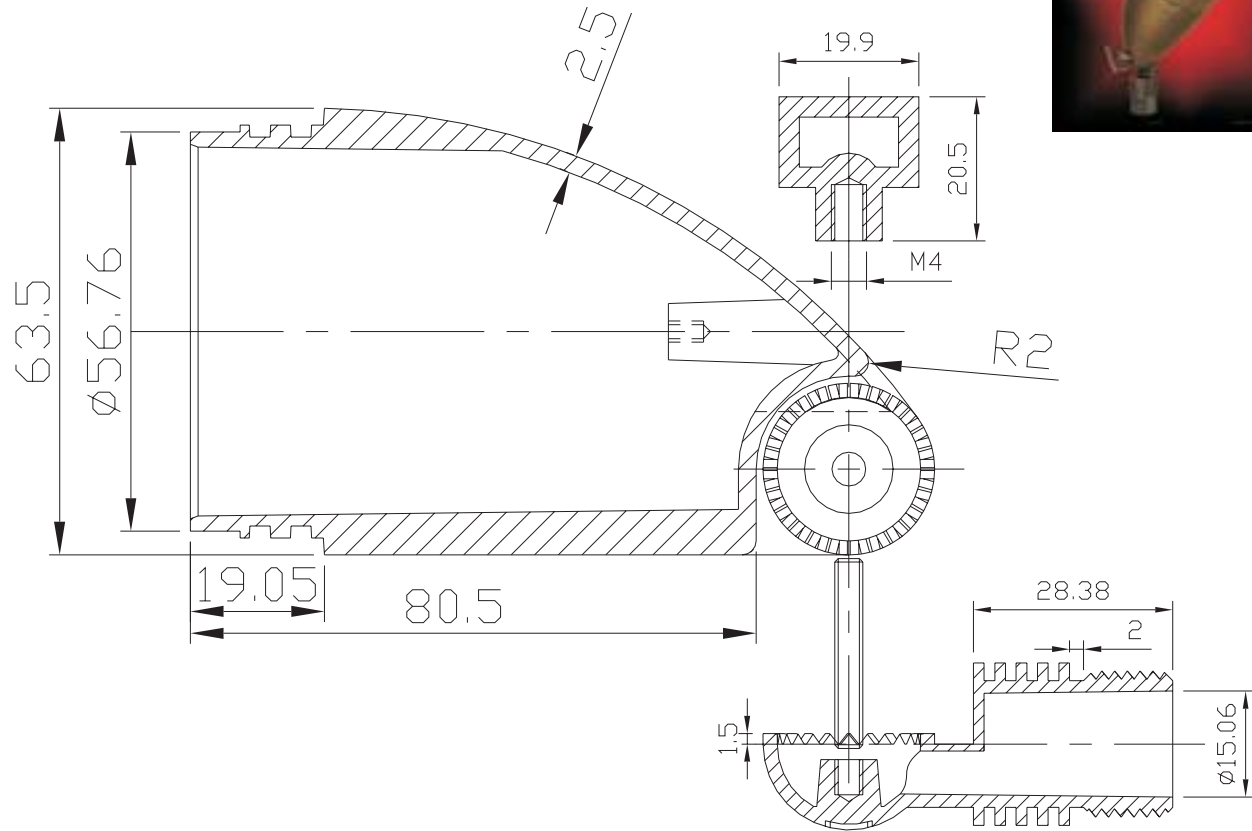
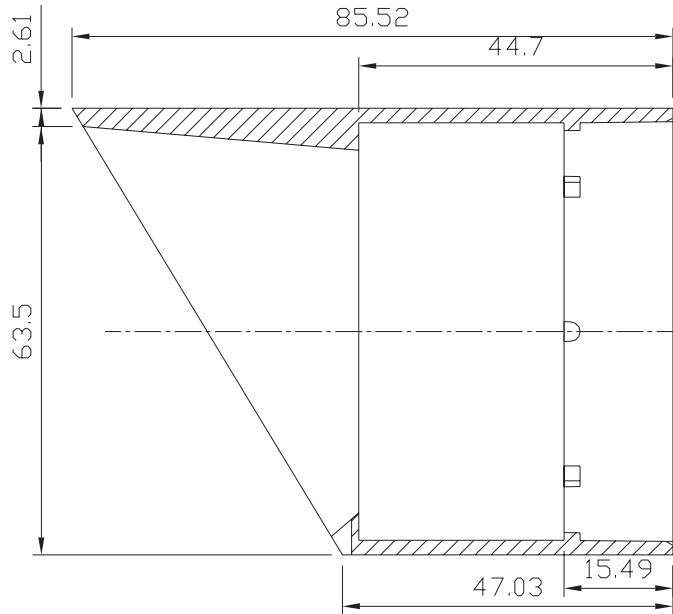

## BQL LIGHTING

MODEL	FRESNO LV-09	SOLID CAST BRASS	
LAMP:		50 WATTS MR16 Max	
FINISH: BRONZE, VERDE & STAINLESS STEEL		12V. DC	1 of 1